

DEP-FILTER 105

We filter your tank



Transparent Filter for the Diesel Microfiltration



TRANSPARENT FILTER

Transparent filter for the diesel microfiltration



Water separation



Filtering cartridge

FG-2 key



TRANSPARENT FILTER

It is suitable for a trustworthy filtration, with hydrophobic system, filtering fiber and paper.

Its transparent vessel allows an ocular and instantaneous inspection and in the event of transferring liquid with impurities, these are retained between the filtering cartridge and the transparent vessel.

It is suitable for diesel. Consult for another liquids.

Its cleaning is EASY.

Technical Data

- Filtration: 5 microns
- Water separation: By hydrophobic filtering paper, with water decanting of 93%
- Capacity: 2 litres
- Transfer capacity: 105l/min
- Upper filter housing: injected Plastic Pa 6.6 , with metallic connections F-212 F1" BSP
- Transparent Housing: OR Cristall
- Inlet / Outlet: F 1" BSP
- Automatic degasifier
- Filtering Capacity: 500.000 litres (normal conditions)
- Installation: On the suction of the pumping equipment
- Operating Pressure: 0,3-0,5bar
- It is supplied with a key for a QUICK replacement of the filtering cartridge, unscrewing its ring

FILTERING CARTRIDGE SPARE OF 5 MICRON PAPER

CF-105

Filtering element made of paper with phenolic resins, corrugating with temperature, with 0,47mm thickness with retention and water separator at 93%. Explosion at 2,2bar

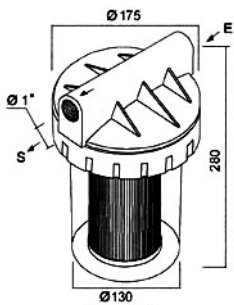

Peso: 1,85Kg
Weight: 1,85Kg

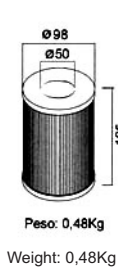

Peso: 0,48Kg
Weight: 0,48Kg

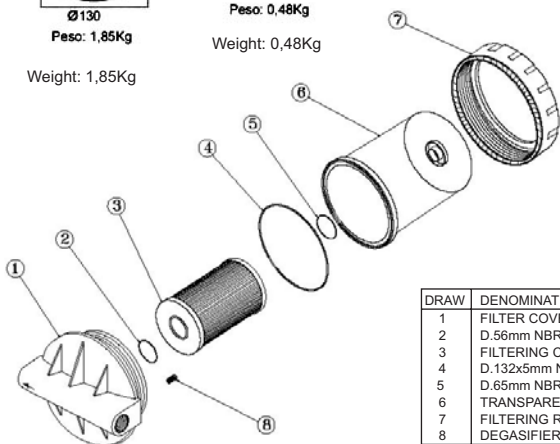

DRAW	DENOMINATION
1	FILTER COVER
2	D.56mm NBR JOINT
3	FILTERING CARTRIDGE
4	D.132x5mm NBR JOINT
5	D.65mm NBR JOINT
6	TRANSPARENT VESSEL
7	FILTERING RING
8	DEGASIFIER

Right filter installation in over and underground tanks

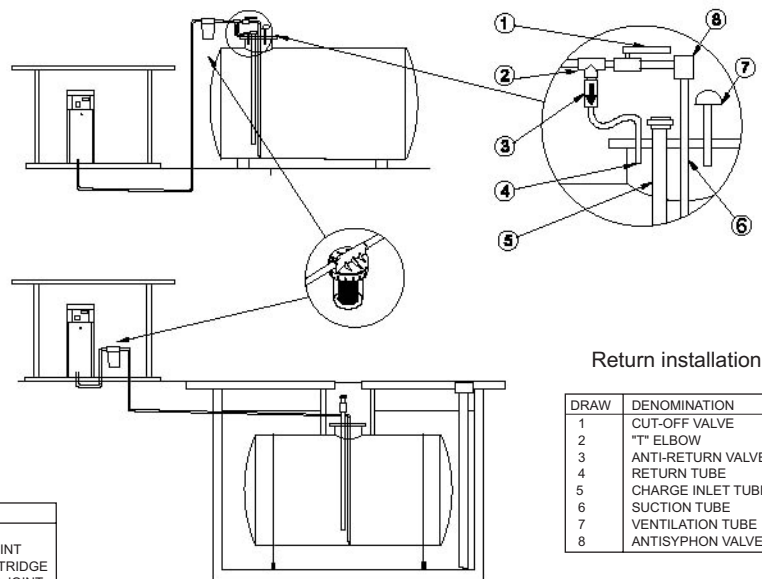

Return installation

DRAW	DENOMINATION
1	CUT-OFF VALVE
2	"T" ELBOW
3	ANTI-RETURN VALVE
4	RETURN TUBE
5	CHARGE INLET TUBE
6	SUCTION TUBE
7	VENTILATION TUBE
8	ANTISYPHON VALVE